

PHYS-1200 PHYSICS II**QUIZ 3****APRIL 29, 2005**

NAME _____

Put a mark in the box next to the section of the course to which you are assigned. If you are not now in the room to which your section is assigned, ***GO TO IT NOW!***

	SECTION NUMBER	EXAMINATION ROOM	INSTRUCTOR	DAY AND TIME THAT SECTION MEETS
	1	DCC 324	SCOTT DWYER	MR 8:00 A.M.
	2	DCC 324	SCOTT DWYER	MR 10:00 A.M.
	3	SAGE 3303	PAUL STOLER	MR 12:00 NOON.
	5	RICKETTS 203	SUSANNE HAUGER	TF 10:00 A.M.
	6	RICKETTS 203	SUSANNE HAUGER	TF 12:00 NOON
	7	DCC 318	SACHINDEV SHENOY	TF 2:00 P.M.
	8	SAGE 3303	PAUL STOLER	MR 2:00 P.M.
	9	DCC 318	SHAWN-YU LIN	MR 12:00 NOON

There are 7 different pages in this quiz, including the cover page. Check now to see that you have all of them.

	CREDIT	GRADE
PART A	40%	
PART B	20%	
PART C-1	20%	
PART C-2	20%	
TOTAL	100%	

All work and answers must be given in the spaces provided on these pages.

NAME _____

PART A. (40%) Each question is worth 5%. In the space provided, to the left of the question number, write the letter corresponding to the best answer to the question.

- ___ 1. The intensity of sound wave *A* is 100 times the intensity of sound wave *B*. Relative to wave *B*, the sound level of wave *A* is:
A. - 2 db B. + 2 db C. + 10 db D. + 20 db E. + 100 db
- ___ 2. The units of index of refraction are:
A. m/s B. s/m C. m/s² D. m⁻¹ E. none of these
- ___ 3. In a Young's double-slit experiment the center of a bright fringe occurs wherever waves from the two slits differ in phase by an integral multiple of:
A. $\frac{\pi}{4}$ B. $\frac{\pi}{2}$ C. π D. $\frac{3\pi}{4}$ E. 2π
- ___ 4. Radio waves are readily diffracted around buildings whereas light waves are negligibly diffracted around buildings. This is because radio waves:
A. are plane polarized
B. have much longer wavelengths than light waves.
C. have much shorter wavelengths than light waves.
D. are nearly monochromatic (single frequency).
E. are either amplitude modulated (AM) or frequency modulated (FM)
- ___ 5. Rank the following electromagnetic radiations according to the energies of their photons, from least to greatest.
1. blue light
2. yellow light
3. x rays
4. microwaves
A. 1, 2, 3, 4 D. 3, 2, 1, 4
B. 4, 2, 1, 3 E. 3, 1, 2, 4
C. 4, 1, 2, 3
- ___ 6. Which of the following is evidence of the wave nature of matter?
A. The photoelectric effect D. Electron tunneling
B. The Compton effect E. The momentum of photons
C. Young's double slit experiment
- ___ 7. A sample of silicon is said to be a "p-type" semiconductor. The term "p-type" means:
A. the silicon is exceptionally pure
B. the silicon has been doped with phosphorous
C. the silicon has a higher potential than normal
D. the silicon has passed a semiconductor proof test
E. none of the above

NAME _____

- ___ 8. The classroom where you regularly meet for your Physics II classes is:
- A. J-ROWL 2C06
 - A. J-ROWL 2C14
 - A. J-ROWL 2C22
 - A. J-ROWL 2C30
 - F. TROY 3031

PART B. (20%)

1. (5%) The sketch shows a small disk, in a vacuum, that is entirely supported by radiation pressure from a powerful laser. The disk reflects all of the radiation, and remains stationary. Suppose the disk is replaced by another disk of the same mass and radius, but the new disk absorbs all of the radiation. What will happen to the new disk? Circle the correct answer.

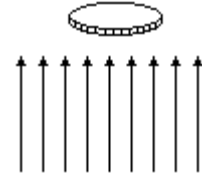

- IT WILL REMAIN STATIONARY**
- IT WILL RISE WITH A CONSTANT VELOCITY**
- IT WILL FALL WITH A CONSTANT VELOCITY**
- IT WILL RISE WITH A CONSTANT ACCELERATION OF 4.9 m/s²**
- IT WILL RISE WITH A CONSTANT ACCELERATION OF 9.8 m/s²**
- IT WILL FALL WITH A CONSTANT ACCELERATION OF 4.9 m/s²**
- IT WILL FALL WITH A CONSTANT ACCELERATION OF 9.8 m/s²**
- MORE INFORMATION IS NEEDED TO ANSWER THIS QUESTION**

2. (5%) Suppose that diffraction alone determines the resolving power of your eyes. You find that you can barely resolve two red dots on a picture that you are viewing. If you increase the general illumination, the diameter of the pupil of each eye will decrease, and if you decrease the illumination the diameter of each pupil will increase. Which, if either, will improve your ability to resolve the two dots? (Circle the correct answer.)

- INCREASE THE ILLUMINATION**
- DECREASE THE ILLUMINATION**
- NEITHER**

NAME _____

3. (10%) An electron is in the $n = 1$ state of a one dimensional potential energy well of width $L = 1.0 \text{ nm}$ ($1.0 \times 10^{-9} \text{ m}$). The wavelength of the electron in that state is 3.14 nm .

a) (5%) Is the potential energy well infinitely deep? Circle the correct answer.

The potential energy well is infinitely deep.

The potential energy well is *not* infinitely deep.

There is not enough information to answer the question.

b) (5%) How did you arrive at the answer to part a)? Circle the explanation that applies. (Not all of them will earn full credit.)

For the $n = 1$ state of an infinite well, $\lambda = L$.

For the $n = 1$ state of an infinite well, $\lambda = 2L$.

For the $n = 1$ state of an infinite well, $\lambda = L/2$.

For the $n = 1$ state of an infinite well, $\lambda = \pi L$.

I guessed.

Some other (honest) method which is explained below. (Explain briefly.)

NAME _____

PART C. (40%) You must show all your work or state your reasoning in order to receive credit.

1. (20%) The sketch below shows a plane light wave of wavelength $\lambda = 5.5 \times 10^{-7}$ m, incident on a *circular* aperture. The light passes through the aperture, and forms a diffraction pattern on a screen that is a distance $D = 10$ m from the aperture. The circular central maximum of the diffraction pattern has a radius of $r = 5.0 \times 10^{-2}$ m.

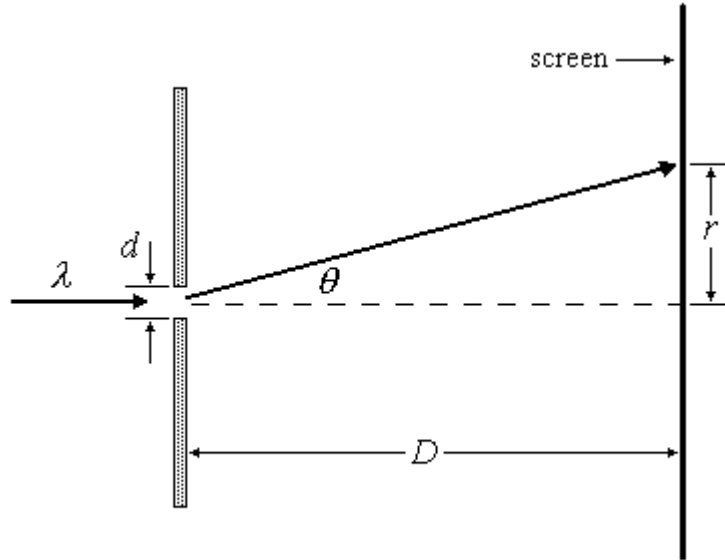

- a) (6%) The light that forms the central maximum delivers power of $P = 7.0$ W to the screen. Find the average intensity of the light that forms the central maximum of the diffraction pattern.

$$I = \text{_____} \text{ units}$$

- b) (8%) How many photons per second are delivered to the circular central maximum of the diffraction pattern?

$$\frac{dN}{dt} = \text{_____} \text{ units}$$

NAME _____

- c) (6%) If the distance D between the aperture and the screen is *decreased*, the average intensity of the central maximum: (Circle the correct choice.)

INCREASES

DECREASES

REMAINS THE SAME

The reason for this choice is: (Circle the correct choice.)

THE AREA OF THE CENTRAL MAXIMUM DECREASES, AND THE POWER INCREASES

THE AREA OF THE CENTRAL MAXIMUM DECREASES, AND THE POWER DECREASES

THE AREA OF THE CENTRAL MAXIMUM DECREASES, AND THE POWER REMAINS THE SAME

NONE OF THE ABOVE

NAME _____

2. (20%) The Fermi energy of silver is 5.5 eV, and the work function for silver is 4.6 eV.
(The charge on an electron is -1.6×10^{-19} C, and its mass is 9.11×10^{-31} kg)

a) (7%) Find the speed of an electron that has kinetic energy equal to the Fermi energy.

$$v_F = \underline{\hspace{2cm}} \text{ units}$$

- b) (6%) Light of wavelength 450 nm (4.5×10^{-7} m) shines on a piece of silver. Do photons of this wavelength have enough energy to eject electrons from the silver? (Circle the correct answer.)

YES

NO

- c) (7%) If your answer to part b) was **YES**, find the maximum kinetic energy of the ejected electrons.

If your answer to part b) was **NO**, find the cutoff wavelength for silver.

$$K_{max} = \underline{\hspace{2cm}} \text{ units}$$

$$\lambda_{cutoff} = \underline{\hspace{2cm}} \text{ units}$$